

Mecalac

COMPACTION ROLLERS
SERIES



**COMPACTION
ROLLERS**

SERIES

Mecalac



TV SERIES

TOUGH EXTERIOR, INTERNAL INNOVATION

With more than 60 years' experience in both design and production, we continue to innovate, boasting a comprehensive portfolio of state-of-the-art equipment specifically developed to revolutionise operations for construction professionals worldwide – saving time, money and labour. Built with innovation in mind, Mecalac compaction rollers are designed to withstand the most demanding tasks. Easy to use controls, intuitive layout and with vibration reduction technology enhances operator comfort and productivity.

Ranging from the versatile MBR71 pedestrian roller to the productive TV1200 tandem roller (and everything in-between), there's the right machine for every application.

HIGH PERFORMANCE, FUEL EFFICIENT KUBOTA STAGE V ENGINE, REXROTH HYDROSTATIC TRANSMISSION

WRAP AROUND STEERING COLUMN FOR IMPROVED OPERATOR COMFORT

HEAVY DUTY FRONT TILTING ENGINE CANOPY PROVIDES EXCELLENT SERVICE ACCESS

EASILY SELECTABLE 1 OR 2 DRUM VIBRATION, INCLUDING DUAL FREQUENCY VIBRATION

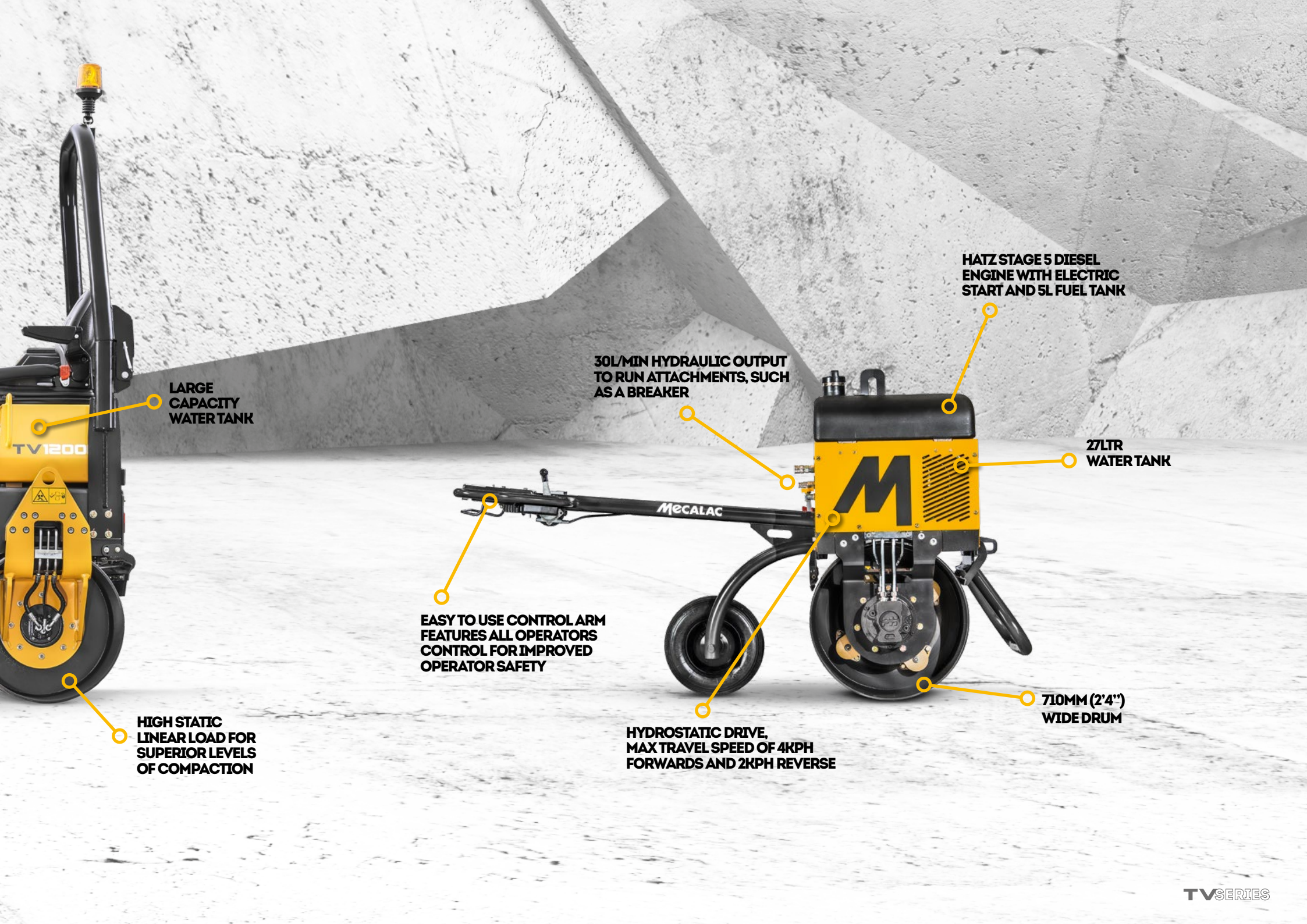

**LARGE
CAPACITY
WATER TANK**

**30L/MIN HYDRAULIC OUTPUT
TO RUN ATTACHMENTS, SUCH
AS A BREAKER**

**HATZ STAGE 5 DIESEL
ENGINE WITH ELECTRIC
START AND 5L FUEL TANK**

**27LTR
WATER TANK**

**EASY TO USE CONTROL ARM
FEATURES ALL OPERATORS
CONTROL FOR IMPROVED
OPERATOR SAFETY**

**HIGH STATIC
LINEAR LOAD FOR
SUPERIOR LEVELS
OF COMPACTION**

**HYDROSTATIC DRIVE,
MAX TRAVEL SPEED OF 4KPH
FORWARDS AND 2KPH REVERSE**

**710MM (2'4")
WIDE DRUM**



SINGLE DRUM ROLLERS

MBR71

Designed for the compaction of asphalt materials, Mecalac pedestrian rollers provide class-leading performance in applications including highway repair, footpaths, cycle lanes, playgrounds and landscaping environments.

The proven design provides superb balance, making it easy to manoeuvre in tight spaces.

Innovative rubber couplings in the drum reduce vibration transfer for low hand-arm (HAV) levels for additional comfort. The MBR71 is fitted with a 'hold to travel' handle so that the hydraulic drive cuts off if the control lever is released.

For added versatility the MBR71 features an all-new tow-behind trailer and hydraulic breaker combination. Inverted suspension ensures the trailer is perfect for low loading, while a new light board design ensures optimum visibility and compliance for road-tow operation.

FEATURES – SINGLE DRUM ROLLERS

- Reliable, air-cooled engine with electrical start for easy start-up
- Effective drum clearing from front and rear scraper bars
- High capacity corrosion free water system ensures drum cleanliness at all times
- Hydrostatic transmission for easy manoeuvrability
- High quality surface finish on drum for improved results on asphalt surfaces





TANDEM VIBRATING ROLLERS

Arguably some of the toughest in the world, the Mecalac range of tandem rollers are designed for the rigorous demands of the plant hire industry.

TV800

The TV800 (featuring with an 800mm (2'7") drum) is perfect for small sites. An optional hydraulic breaker outlet provides 30L/min flow rate (Category 2), removing the need for an additional powerpack or compressor on site, further increasing versatility.

TV900

With a 900mm (2'11") drum, high compaction productivity is achieved by the TV900's mass exciter system, which delivers high dynamic force, optimised balance between frequency and amplitude provides ultimate versatility in meeting all kinds of job site conditions. An optional hydraulic breaker outlet provides 30L/min flow rate (Category 2).

TV1000

Setting the standard for asphalt and granular layers compaction, the TV1000 is operator friendly and highly productive. Hydrostatic power management provides excellent hill-climbing ability and, when combined with superb articulation delivering a tight turning circle, are highly manoeuvrable. The TV1000 features 1000mm (3'3") wide drums.





TANDEM VIBRATING ROLLERS

TV1200

Bringing new life to a proven classic, the TV1200 features an all-new vacuum formed bonnet, revised side arm, LED lights and a fully-refreshed livery. A water-cooled diesel engine and renowned mass exciter system completes the set-up, guaranteeing a reliable roller with outstanding performance.

FEATURES – TANDEM VIBRATING ROLLERS

- Rugged design to withstand plant hire industry conditions
- Water-cooled diesel engines provide excellent reliability, low noise and low emissions
- High-static linear loads reduce the number of passes
- Two frequencies provide enhanced versatility
- Optional pressure fed water sprinkler provides greater flow regulation for improved cleaning capability







TECHNICAL SPECIFICATIONS

→ MBR-71 / TV800 / TV900 / TV1000 / TV1200



TECHNICAL SPECIFICATIONS



Compaction Roller Range	MBR71	TV800	TV900	TV1000	TV1200
Operating Weight kg (lbs)	513 (1130)	1559 (3437)	1568 (3457)	2570 (5665.8)	2925 (6448.5)
Static Linear Load kg/cm (lb/in)	7.2 (40.3)	9.7 (54.3)	8.7 (48.7)	12.85 (71.9)	12.18 (68.2)
Frequency VPM	3900	2760 / 3120	2760 / 3120	2880 / 3360	2880 / 3360

TECHNICAL DATA **PEDESTRIAN ROLLER MBR71**

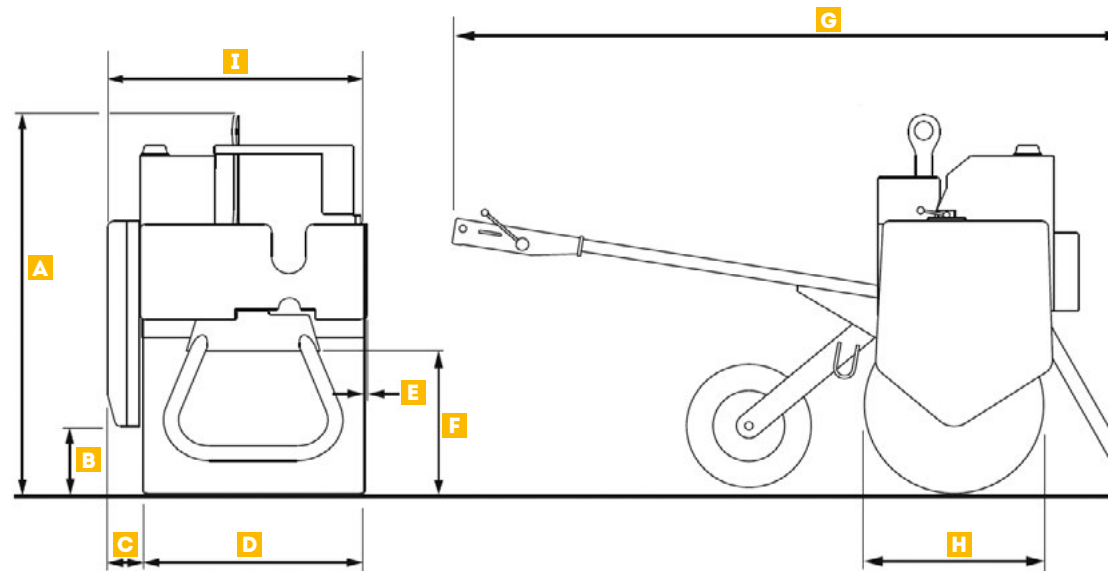

DIMENSIONS mm (ft in)		DATA
A	Overall Height	1225 (4')
B	Curb Clearance - Farside	468 (1'6")
C	Overhang - Farside	38 (1.5")
D	Drum Width	710 (2'3")
E	Overhang - Curbside	25 (1")
F	Curb Clearance - Curbside	380 (1'3")
G	Overall Length	2187 (7'2")
H	Drum Diameter	Ø575 (1'11")
I	Machine Width	772 (2'6")
	Drum Shell Thickness (not shown)	8

TECHNICAL DATA **PEDESTRIAN ROLLER MBR71**

PERFORMANCE	DATA
Total Static Basic Weight kg (lbs)	496 (1093)
Operating Weight kg (lbs) CECE	513 (1130)
Static Linear Load kg/cm (lb/inch)	7.2 (40.3)
Frequency - Hz (VPM)	65 (3900)
Amplitude (mm)	0.57
Centrifugal Force kN (lbf)	15 (3372)
Gradeability - without Vibration	33%
Gradeability - with Vibration	25%

ENGINE & DRIVE	
Engine Make	Hatz
Engine Model	1B50T
Cylinders	1
Displacement cc (in ³)	517 (31.5)
Cooling	Air
Power - kW (HP) (DIN ISO 1585)	7.3 (9.8)
Operating Speed (rpm)	3000
Fuel Type	Diesel
Drive	Hydrostatic
Maximum Travel Speed (kph) - Forwards	4 (2.5)
Maximum Travel Speed (kph) - Reverse	2 (1.2)
Braking System - Service	Dynamic Hydrostatic
Braking System - Parking	Spring apply hydraulic release
Start Type	Electric

CAPACITIES	
Hydraulic Tank Capacity ltr (gallons (US))	12.5 (3.3)
Fuel Tank Capacity ltr (gallons (US))	5 (1.32)
Water Tank Capacity ltr (gallons (US))	27 (7.13)

EMISSIONS	
Noise (dB) - LwA (2000/14/EC / ISO 4871)	92dB
Engine Emissions	EU Stage V / U.S. EPA Tier 4 Final*
Hand Arm Vibration (HAV) - (EN500-4)	3.6m/s ²

EXCITER	
Type	Single Shaft
Drive	Hydraulic Motor

WATER SPRAY SYSTEM	
System Type	Gravity Fed with Non-Corrosive Spray Bar

DRUM SCRAPER BARS	
System Type	Heavy Duty Adjustable - Front and Rear

STANDARD EQUIPMENT

Gravity Fed Water System
Drum Scraper Bars Front and Rear
Low Maintenance Battery (12V)
Emergency Release Free Wheel Valve
Heavy Duty Central Lifting Point
Battery Isolator
Emergency Stop
Front Prop Stand
Rear Jockey Wheel
Electric Starting
Hour Meter
30L/min Hydraulic Take-off Valve

OPTIONAL EQUIPMENT

Stanley BR50 Vibro-Damped Hydraulic Breaker with Tools, Valve and Hosing (light use only)
Stanley BR67 Vibro-Damped Hydraulic Breaker with Tools, Valve and Hosing (must be carried on towing vehicle)
'Towit' Tow-Behind Trailer with Storage Box, Prop-Stand, Number Plate Lighting and Road Lighting
'Towit' Tow-Behind Trailer, Longer Break-away Tether Cable with Clip on Hook

**Standard and optional equipment may vary.
Consult your Mecalac dealer for details.**

*Depending on your Local Legislation - Environmental Protection Agency (EPA)

NOTE

METRIC MEASUREMENTS ARE THE CRITICAL VALUES

- 1 Litre = 0.26417 US Liquid Gallons
- 1 Litre = 0.21997 Imperial Liquid Gallons

TECHNICAL DATA

COMPACT TANDEM ROLLERS

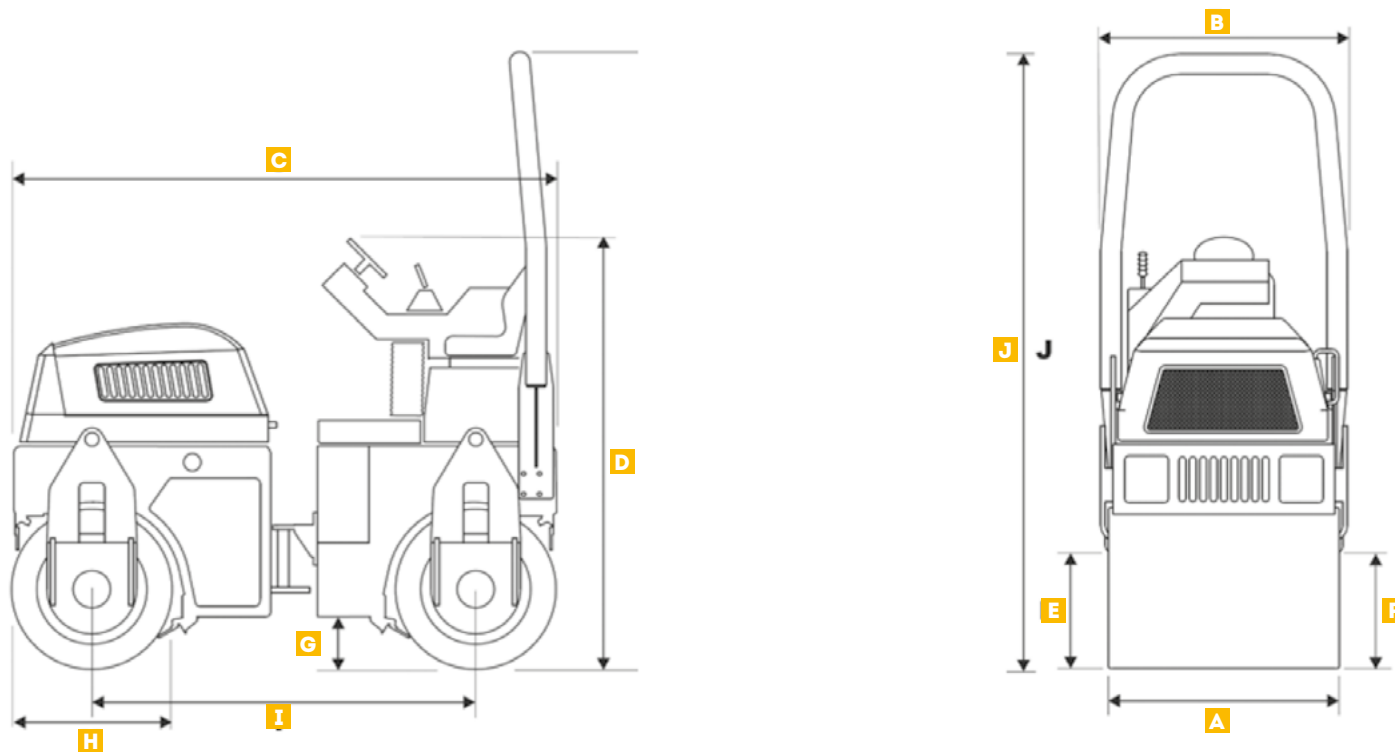

DIMENSIONS mm (ft in)	TV800	TV900	TV1000	TV1200
A Drum Width	800 (2'7")	900 (2'11")	1000 (3'3")	1200 (3'11")
B Overall Width	870 (2'10")	970 (3'2")	1070 (3'6")	1270 (4'2")
C Overall Length	1860 (6'1")	1860 (6'1")	2375 (7'10")	2375 (7'10")
D Height to Top of Steering Wheel (Transport Height)	1530 (5')	1530 (5')	1940 (6'4")	1940 (6'4")
E Curb Clearance - Right	420 (1'5")	420 (1'5")	555 (1'10")	555 (1'10")
F Curb Clearance - Left	390 (1'3")	390 (1'3")	490 (1'7")	490 (1'7")
G Ground Clearance	200 (8")	200 (8")	230 (9")	230 (9")
H Drum Diameter	Ø550 (1'10")	Ø550 (1'10")	Ø700 (2'4")	Ø700 (2'4")
I Wheelbase	1260 (4'2")	1260 (4'2")	1675 (5'6")	1675 (5'6")
J Height to Top of ROPS frame	2400 (7'10")	2400 (7'10")	2650 (8'8")	2650 (8'8")
Overhang - Left / Right	35/35 (1.3"/1.3")	35/35 (1.3"/1.3")	35/35 (1.3"/1.3")	35/35 (1.3"/1.3")

TECHNICAL DATA

COMPACT TANDEM ROLLERS

PERFORMANCE	TV800	TV900	TV1000	TV1200
Total Static Basic Weight kg (lbs)	1446 (3188)	1455 (3208)	2385 (5258)	2740 (6040.6)
Operating Weight kg (lbs) CECE	1559 (3437)	1568 (3457)	2570 (5665.8)	2925 (6448.5)
Static Linear Load kg/cm (lb/inch)	9.7 (54.3)	8.7 (48.7)	12.85 (71.9)	12.18 (68.2)
Frequency - Hz (VPM)	46/52 (2760/3120)		49/63 (2940/3780)	
Amplitude (mm)	0.5	0.5	0.5	0.6
Centrifugal Force kN (lbf)	10/12.5 (2248/2810)	10/12.5 (2248/2810)	18/29 (4046/6519)	24/38 (5395/8542)
Gradeability - without Vibration	30%	30%	30%	30%
Gradeability - with Vibration	40%	40%	40%	40%
Drum Shell Thickness mm (ft in)	10 (0.3")	10 (0.3")	10 (0.3")	10 (0.3")
Drum Finish	Machine Chamfered Edges			
Vibrating Drums	Front and Rear or Rear Only (selectable)			
ENGINE & DRIVE	TV800	TV900	TV1000	TV1200
Engine Make	Kubota	Kubota	Kubota	Kubota
Engine Model	D1005	D1005	D1703-M	D1703-M
Cylinders	3	3	3	3
Displacement cc (in ³)	1001 (61.08)	1001 (61.08)	1647 (100.5)	1647 (100.5)
Cooling	Water	Water	Water	Water
Power - kW (HP)	17.5 (23)	17.5 (23)	18.5 (25)	18.5 (25)
Operating Speed (rpm)	2500/3000	2500/3000	2300/2800	2300/2800
Fuel Type	Diesel	Diesel	Diesel	Diesel
Engine Emissions	EU Stage V / U.S. EPA Tier 4 Final*			
Drive (both drums)	Hydrostatic	Hydrostatic	Hydrostatic	Hydrostatic
Travel Speed kph (mph)	8 (4.9)	8 (4.9)	8 (4.9)	10 (6.2)
Braking System – Service	Dynamic Hydrostatic (via propulsion system)			
Braking System – Parking	Spring Apply / Hydraulic Release on both drums			
WATERING SYSTEM	TV800	TV900	TV1000	TV1200
Tank Capacity ltr (gallons (US))	86 (22.7)	86 (22.7)	180 (47.5)	180 (47.5)
Spray Modes	Gravity / Pressure			
ELECTRICAL SYSTEM	TV800	TV900	TV1000	TV1200
Battery (volts)	12V DC	12V DC	12V DC	12V DC
Alternator (amp)	30	30	55	55
LUBRICATION SYSTEM	TV800	TV900	TV1000	TV1200
Type	Grease - open loop, parallel circuit with centralised greasing points			
EMISSIONS	TV800	TV900	TV1000	TV1200
Engine	EU Stage V / U.S. EPA Tier 4 Final*			
Noise (dBA)	106	106	106	106
CAPACITIES	TV800	TV900	TV1000	TV1200
Hydraulic Tank Capacity ltr (gallons (US))	28 (7.4)	28 (7.4)	44 (11.6)	44 (11.6)
Fuel Tank Capacity ltr (gallons (US))	18 (4.7)	18 (4.7)	44 (11.6)	44 (11.6)
Water Tank Capacity ltr (gallons (US))	86 (22.7)	86 (22.7)	180 (47.5)	180 (47.5)
STEERING	TV800	TV900	TV1000	TV1200
Steering Type	Centrepoint Articulation - Double acting (via single hydraulic ram)			
Inside Turn Radius mm (ft in)	1950 (6'5")	1900 (6'3")	2625 (8'7")	2525 (8'3")
Outside Turn Radius mm (ft in)	2820 (9'3")	2870 (9'5")	3695 (12'1")	3795 (12'5")
Frame Articulation (degrees)	30	30	30	30
Frame Oscillation (degrees)	8	8	15	15

*Depending on your Local Legislation - Environmental Protection Agency (EPA)

STANDARD EQUIPMENT

Fixed ROPS Frame
Integral Lifting Points
Amber Beacon
Fuel and Hydraulic Oil Tanks Level Gauges (TV1000 to TV1200)
Vandal Protection Package - Lockable Instrument Cover to Deter Vandals / Thieves
Site Lights (Dependent on Region)
Centralised Greasing Points for Easy Servicing
Gravity Fed Water System (TV800 to TV1200H only)
Vibration Insulated Operator's Station
Deluxe Operator's Seat with Lap Belt and Traction Cut-out Switch - Automatic Stop if Operator Stands Up During Operation
Drum Scraper Bars Front and Rear (both drums)
Articulation Lock Bar
Sliding Operator Seat (TV1200H only)
Removable Plastic Water and Oil Tanks for Easy Servicing
Fault Finding Lights on Instrument Panel
Low Maintenance Battery
Steering Knob
Single Piece Tilting Engine Hood
6 in 1 Control Lever
Emergency Release Free Wheel Valve (for towing)
Hour Meter

OPTIONAL EQUIPMENT

Folding ROPS Frame
Audible Reversing Alarm
Road Lights - UK Road Traffic Act Compliant (TV800 to TV1200H)
Sun Canopy (TV1000 to TV1200 only)
Pressurised Water Spray (TV800 to TV1200H)
Hydraulic Breaker Attachment, Tool, Valve and Hosing - 30L/min (TV800 to TV900)

Standard and optional equipment may vary.
Consult your Mecalac dealer for details.

NOTE

METRIC MEASUREMENTS ARE THE CRITICAL VALUES

- 1 Litre = 0.26417 US Liquid Gallons
- 1 Litre = 0.21997 Imperial Liquid Gallons

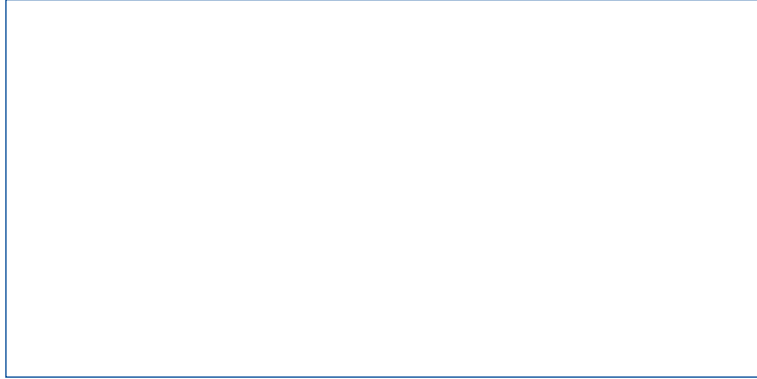

MECALAC FRANCE S.A.S.
2, avenue du Pré de Challes
Parc des Glaisins – CS 40230
Annecy-le-Vieux
FR - 74942 Annecy Cedex
Tel. +33 (0)4 50 64 01 63

**MECALAC BAUMASCHINEN
GMBH**
Am Friedrichsbrunnen
D-24782 Búdelsdorf
Tel. +49 (0)43 31/3 51-319

**MECALAC CONSTRUCTION
EQUIPMENT UK LTD**
Unit 1, Mallory Way
Gallagher Business Park
Coventry, CV6 6PB, UK
Tel. +44 (0)24 7633 9400

**MECALAC İŞ MAKİNELERİ
SAN. VE TİC. LTD. ŞTİ.**
Ege Serbest Bölgesi
Zafer SB Mahallesi Gündüz Sokak No:17/1
35410, Gazimür - İzmir - TÜRKİYE
Tel. +90 232 220 11 15



WWW.MECALAC.COM